



FSP04

- Network Rail Product Acceptance Certificate PA05/07058.
- Compliant to NR/L2/SIGELP27409 Issue 2.
- All FSP04s come fitted with RSP's unique removable and split-able gland plates.
- Suitable for SIN119 Legacy Installation upgrades.

	FSP04 Type 01 DLLF4P01	FSP04 Type 02 DLLF4P02	FSP04 Type 03 DLLF4P03 DLLF2P20-02	FSP04 Type 04 DLLF4P04 DLLF2P21-02	FSP04 Type 05 DLLF4P05 DLLF2P22-02	FSP04 Type 06 DLLF4P06	FSP04 Type 07 DLLF4P07	FSP04 Type 08 DLLF4P08	FSP04 Type 09 DLLF4P09	FSP04 Type 10 DLLF4P10
Class	II	II	II	II	II	II	II	II	II	II
Feeder Switches	1	1	1	1	2	2	1	1	2	2
Functional Supplies	1	1	1	1	1	1	2	2	2	2
Feeder Cable Size (Cu or Al)	6-50mm ²	6-50mm ²	16-120mm ²	16-120mm ²	16-120mm ²	16-120mm ²	16-120mm ²	16-120mm ²	16-120mm ²	16-120mm ²
Type of Fuses	IEC	BS88	IEC	BS88	IEC	BS88	IEC	BS88	IEC	BS88
Dimensions (mm)	W=300 H=200 D=224	W=300 H=200 D=224	W=300 H=300 D=224	W=300 H=300 D=224	W=300 H=300 D=224	W=300 H=300 D=224	W=400 H=300 D=221	W=400 H=300 D=221	W=400 H=300 D=221	W=400 H=300 D=221
Weight	5Kg	5Kg	6Kg	6Kg	6Kg	6Kg	7.5Kg	7.5Kg	7.5Kg	7.5Kg
Railway Cat No.	092/002324	092/002325	092/002326	092/002327	092/002328	092/002329	092/002330	092/002331	092/002332	092/002333
Additional Comments									Functional supplies share a common fuse	Functional supplies share a common fuse

FSP04 - Type 01

FSP04 Switchgear Assembly - Type 01

- Railway Cat No. 092/002324.
- RSP Part No. DLLF4P01.
- Class II Distribution Enclosure for 650V Signalling Systems.

Key Features:

- Combined Ring Power IN/OUT Isolator.
- Compatible with Copper (Cu) or Aluminium (Al) Feeder Cables from 6-50mm².
- One Switched and Fused Output Functional Supply.
- Functional Supply Fuse Carriers IEC60269 (ABB 10x38mm).
- Compliant to Network Rail specification NR/L2/ELP/27409 Issue 2.
- Dimensions W=300mm x H=200mm x D=224mm.
- Weight = 5Kg.

Support

All products come with a standard 12 month warranty with an option to extend if required and a minimum 35 year life expectancy. RSP has an experienced team on hand to provide ongoing support pre, during and after sales.



Need a tailored design?

Our IRSE licensed designers can give you the bespoke solution you need.
Call us on **01752 969321** or you can fill out *our online form*



FSP04 - Type 01

FSP04 Type 01

WIRING DIAGRAM

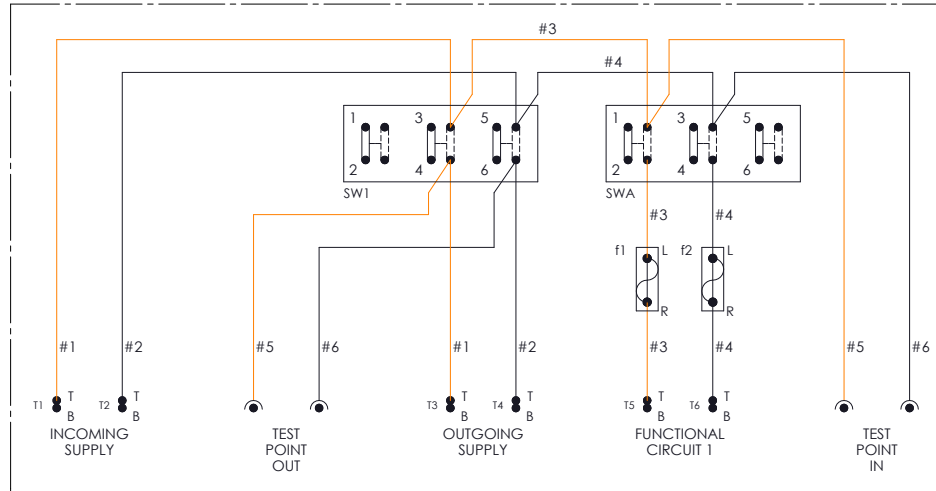

DIMENSIONING

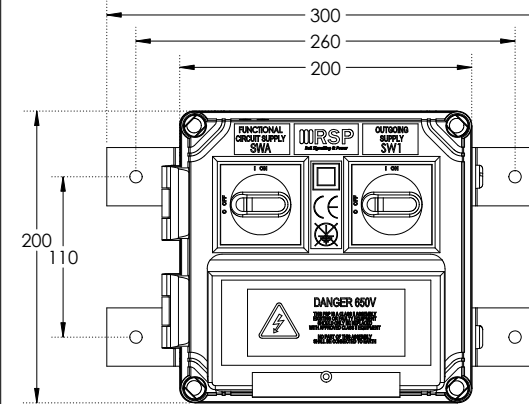

INTERNAL VIEW

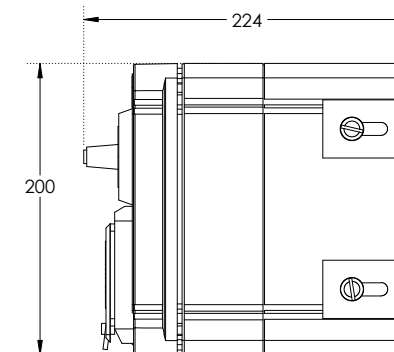
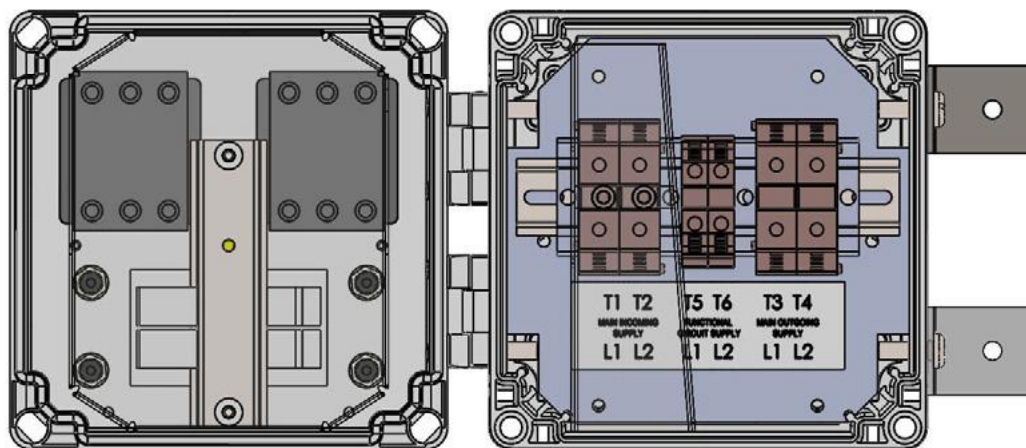

FSP04 - Type 02

FSP04 Switchgear Assembly - Type 02

- Railway Cat No. 092/002325.
- RSP Part No. DLLF4P02.
- Class II Distribution Enclosure for 650V Signalling Systems.

Key Features:

- Combined Ring Power IN/OUT Isolator.
- Compatible with Copper (Cu) or Aluminium (Al) Feeder Cables from 6-50mm².
- One Switched and Fused Output Functional Supply.
- Functional Supply Fuse Carriers BS88.
- Compliant to Network Rail specification NR/L2/ELP/27409 Issue 2.
- Dimensions W=300mm x H=200mm x D=224mm.
- Weight = 5Kg.

Support

All products come with a standard 12 month warranty with an option to extend if required and a minimum 35 year life expectancy. RSP has an experienced team on hand to provide ongoing support pre, during and after sales.



Contact us to order or get more info

Call us on **01752 969321**

Alternately you can fill out *our online form*



FSP04 - Type 02

FSP04 Type 02

WIRING DIAGRAM

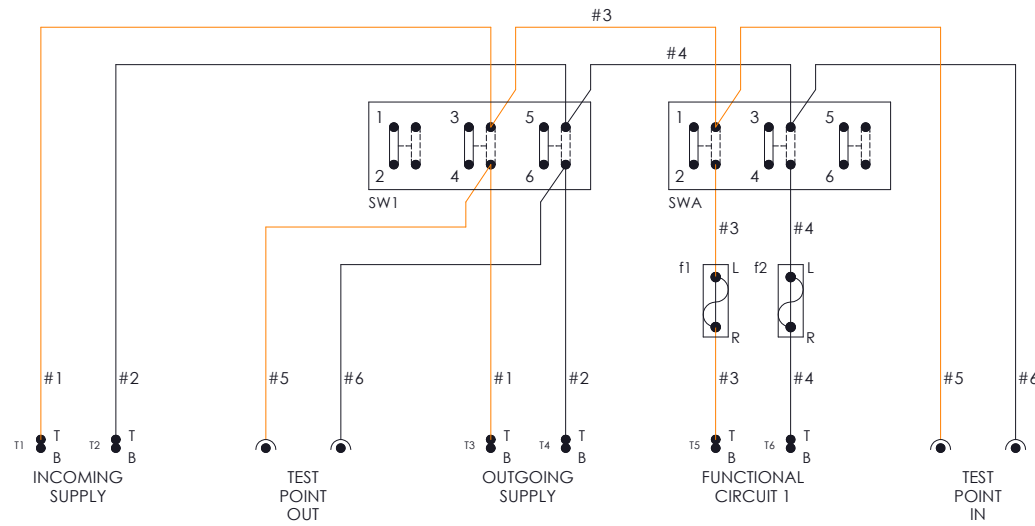

DIMENSIONING

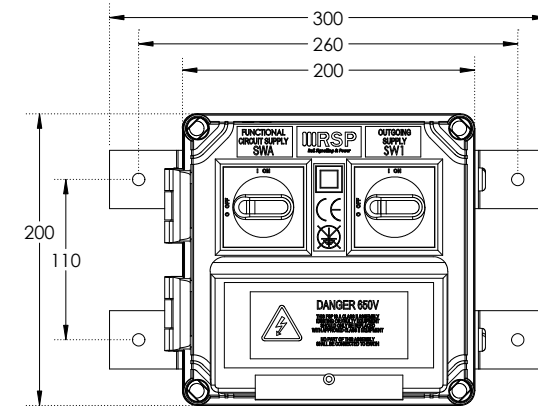

INTERNAL VIEW

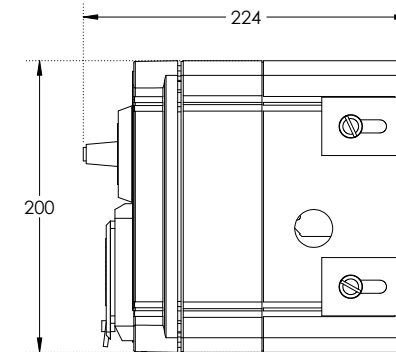
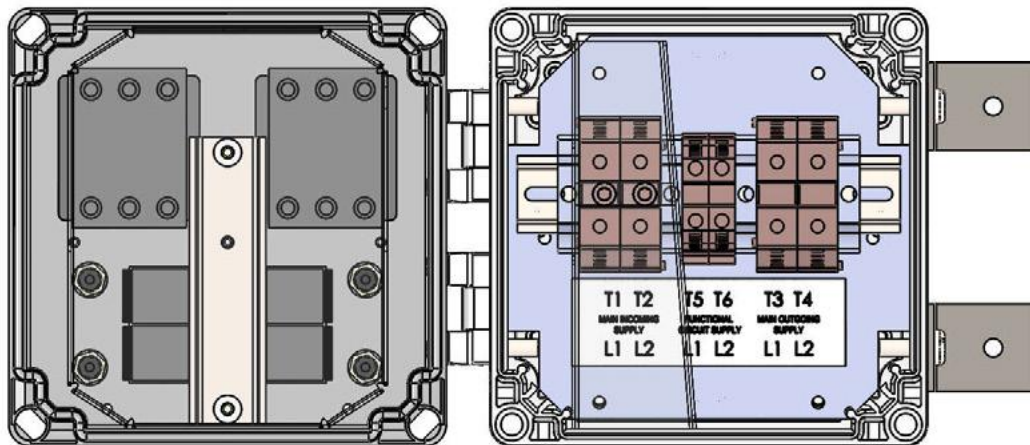

FSP04 - Type 03

FSP04 Switchgear Assembly - Type 03

- Railway Cat No. 092/002326.
- RSP Part No. DLLF4P03.
- Class II Distribution Enclosure for 650V Signalling Systems.

Key Features:

- Combined Ring Power IN/OUT Isolator.
- Compatible with Copper (Cu) or Aluminium (Al) Feeder Cables from 16-120mm².
- One Switched and Fused Output Functional Supply.
- Functional Supply Fuse Carriers IEC60269 (ABB 10x38mm).
- Compliant to Network Rail specification NR/L2/ELP/27409 Issue 2.
- Dimensions W=300mm x H=300mm x D=224mm.
- Weight = 6Kg.

Support

All products come with a standard 12 month warranty with an option to extend if required and a minimum 35 year life expectancy. RSP has an experienced team on hand to provide ongoing support pre, during and after sales.



Contact us to order or get more info

Call us on **01752 969321**

Alternately you can fill out *our online form*



FSP04 - Type 03

FSP04 Type 03

WIRING DIAGRAM

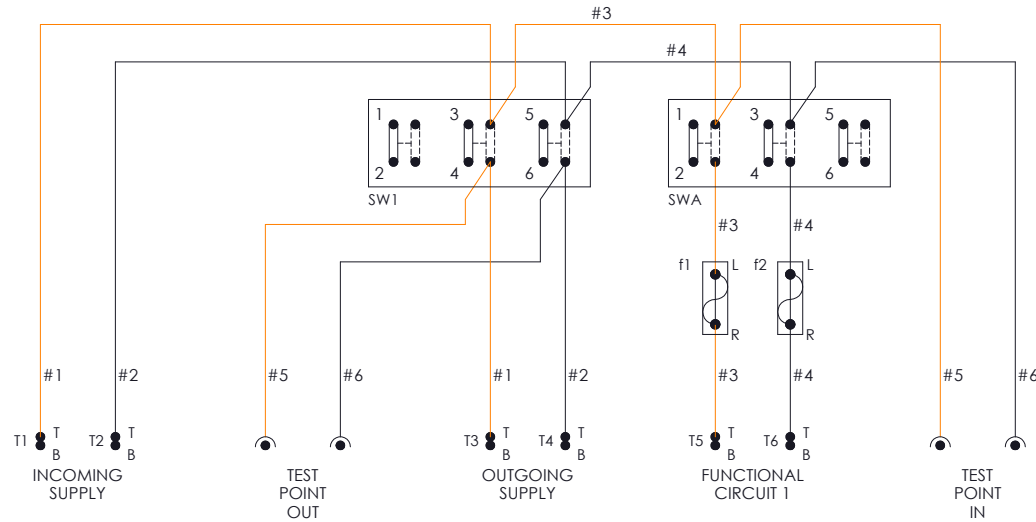

DIMENSIONING

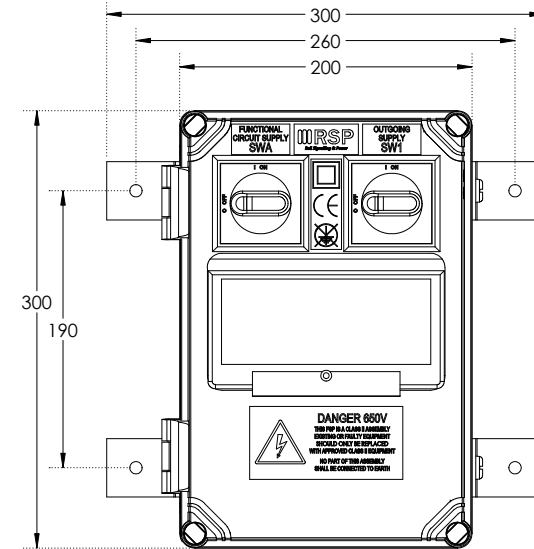

INTERNAL VIEW

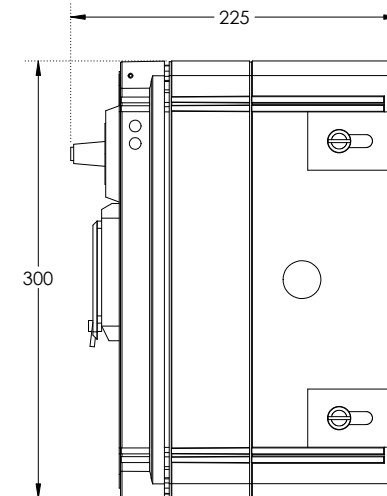
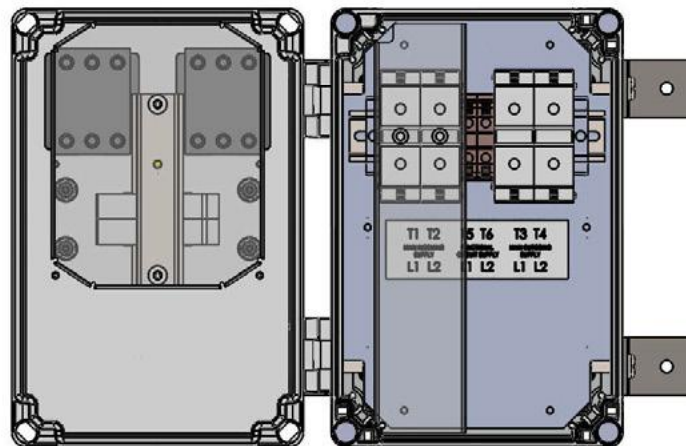



FSP04 - Type 04

FSP04 Switchgear Assembly - Type 04

- Railway Cat No. 092/002327.
- RSP Part No. DLLF4P04.
- Class II Distribution Enclosure for 650V Signalling Systems.

Key Features:

- Combined Ring Power IN/OUT Isolator.
- Compatible with Copper (Cu) or Aluminium (Al) Feeder Cables from 16-120mm².
- One Switched and Fused Output Functional Supply.
- Functional Supply Fuse Carriers BS88.
- Compliant to Network Rail specification NR/L2/ELP/27409 Issue 2.
- Dimensions W=300mm x H=300mm x D=224mm.
- Weight = 6Kg.

Support

All products come with a standard 12 month warranty with an option to extend if required and a minimum 35 year life expectancy. RSP has an experienced team on hand to provide ongoing support pre, during and after sales.



Contact us to order or get more info

Call us on **01752 969321**

Alternately you can fill out *our online form*



FSP04 - Type 04

FSP04 Type 04

WIRING DIAGRAM

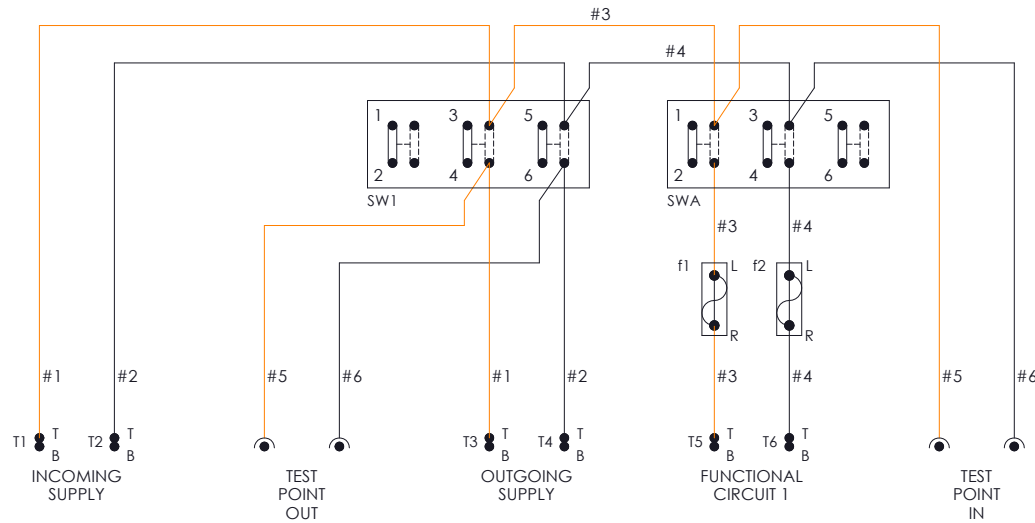

DIMENSIONING

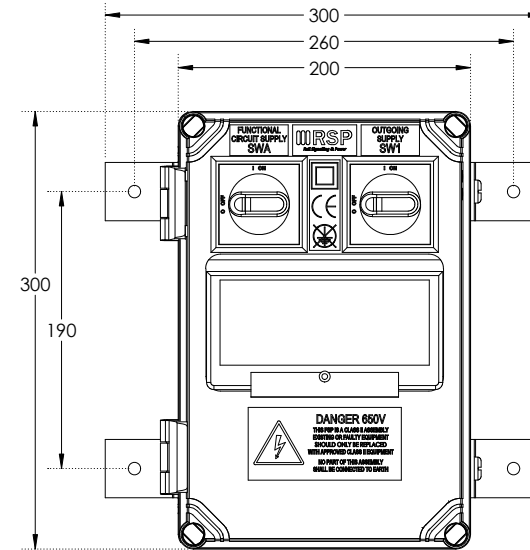

INTERNAL VIEW

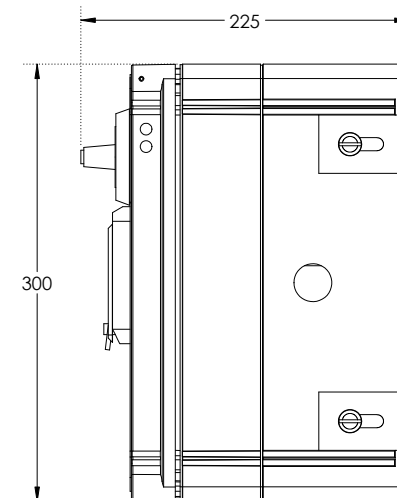
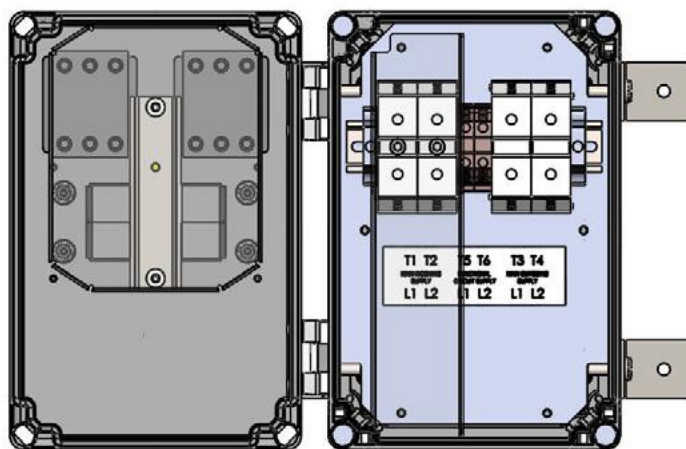

FSP04 - Type 05

FSP04 Switchgear Assembly - Type 05

- Railway Cat No. 092/002328.
- RSP Part No. DLLF4P05.
- Class II Distribution Enclosure for 650V Signalling Systems.

Key Features:

- Dedicated Ring Power IN and OUT Isolators.
- Compatible with Copper (Cu) or Aluminium (Al) Feeder Cables from 16-120mm².
- One Switched and Fused Output Functional Supply.
- Functional Supply Fuse Carriers IEC60269 (ABB 10x38mm).
- Compliant to Network Rail specification NR/L2/ELP/27409 Issue 2.
- Dimensions W=300mm x H=300mm x D=224mm.
- Weight = 6Kg.

Support

All products come with a standard 12 month warranty with an option to extend if required and a minimum 35 year life expectancy. RSP has an experienced team on hand to provide ongoing support pre, during and after sales.



Contact us to order or get more info

Call us on **01752 969321**

Alternately you can fill out *our online form*



FSP04 - Type 05

FSP04 Type 05

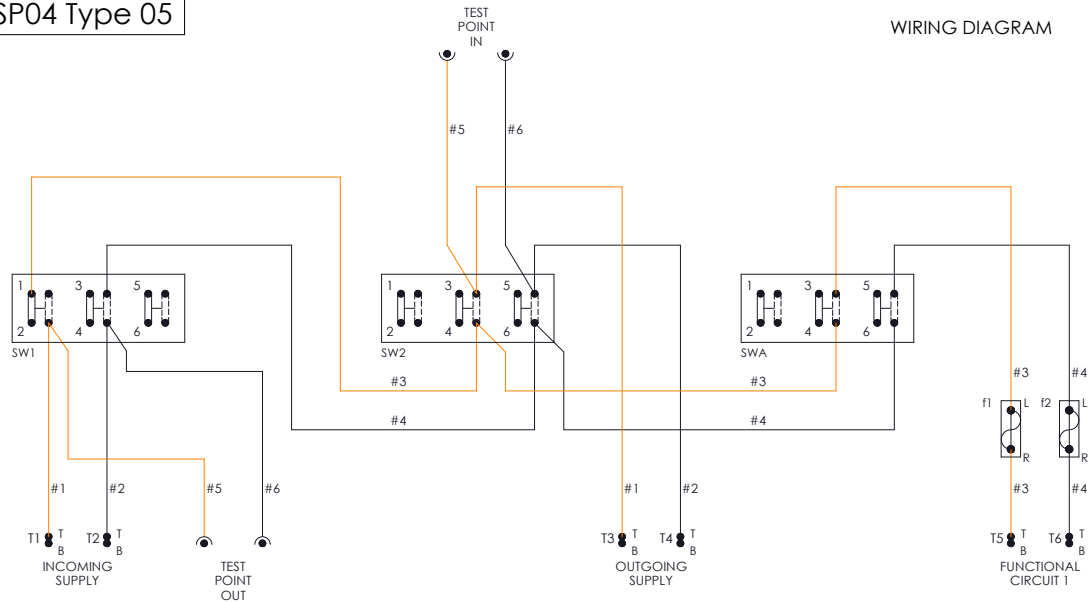

DIMENSIONING

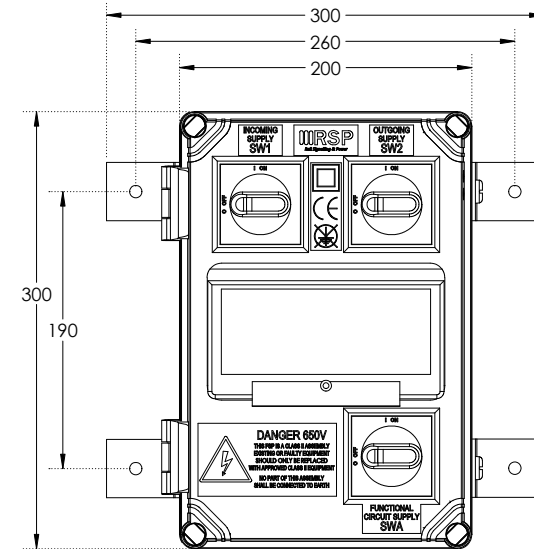

INTERNAL VIEW

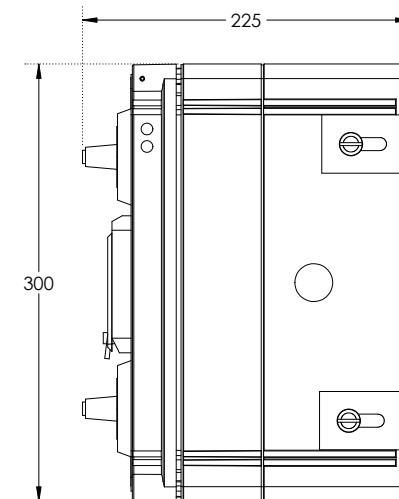
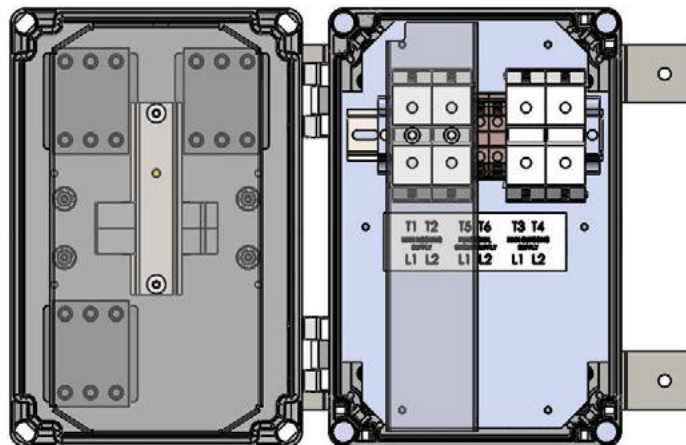

FSP04 - Type 06

FSP04 Switchgear Assembly - Type 06

- ❑ Railway Cat No. 092/002329.
- ❑ RSP Part No. DLLF4P06.
- ❑ Class II Distribution Enclosure for 650V Signalling Systems.

Key Features:

- ❑ Dedicated Ring Power IN and OUT Isolators.
- ❑ Compatible with Copper (Cu) or Aluminium (Al) Feeder Cables from 16-120mm².
- ❑ One Switched and Fused Output Functional Supply.
- ❑ Functional Supply Fuse Carriers BS88.
- ❑ Compliant to Network Rail specification NR/L2/ELP/27409 Issue 2.
- ❑ Dimensions W=300mm x H=300mm x D=224mm.
- ❑ Weight = 6Kg.

Support

All products come with a standard 12 month warranty with an option to extend if required and a minimum 35 year life expectancy. RSP has an experienced team on hand to provide ongoing support pre, during and after sales.



Contact us to order or get more info

Call us on **01752 969321**

Alternately you can fill out *our online form*



FSP04 - Type 06

FSP04 Type 06

WIRING DIAGRAM

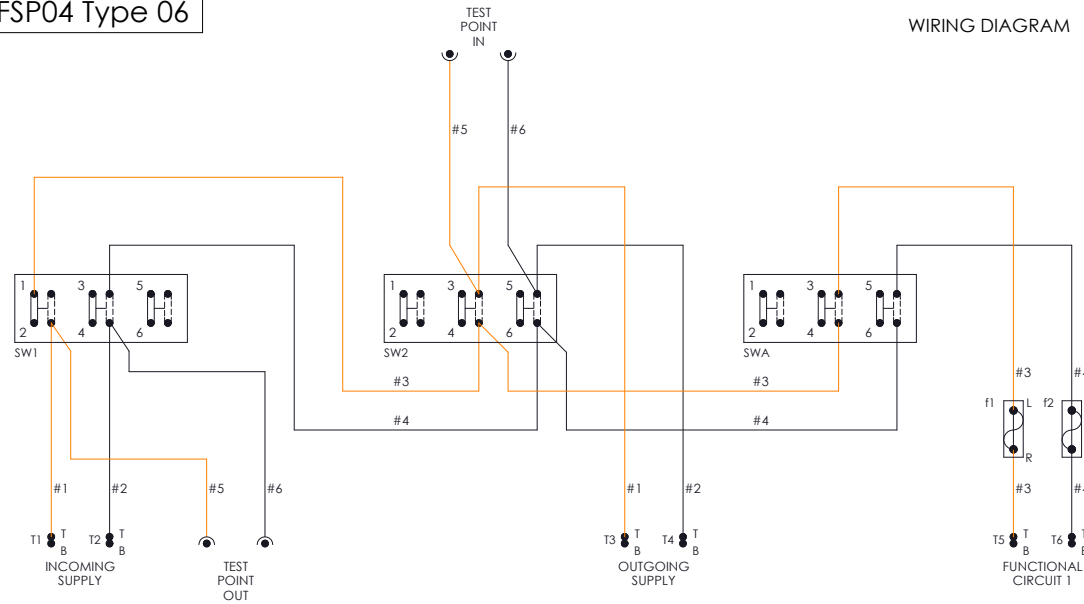

DIMENSIONING

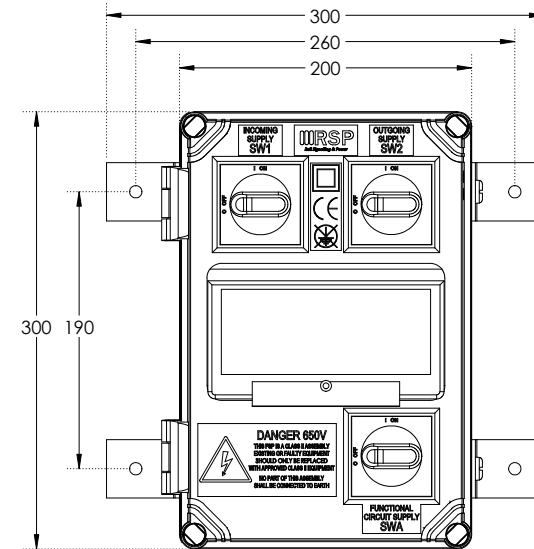

INTERNAL VIEW

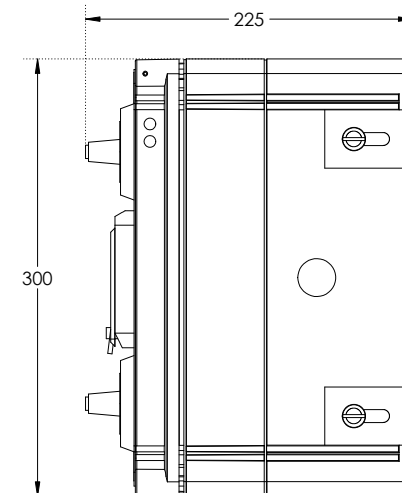
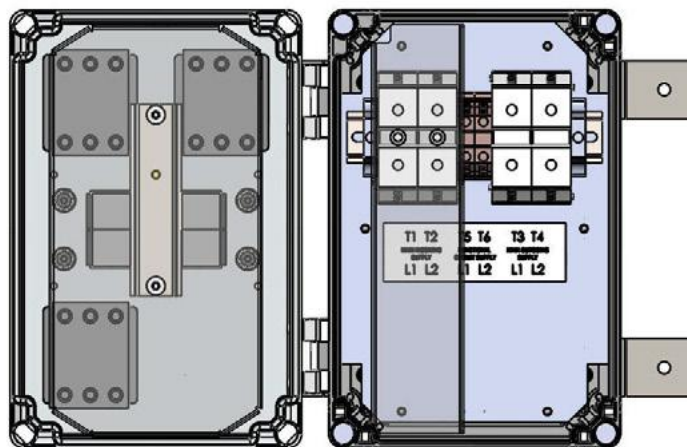

FSP04 - Type 07

FSP04 Switchgear Assembly - Type 07

- Railway Cat No. 092/002330.
- RSP Part No. DLLF4P07.
- Class II Distribution Enclosure for 650V Signalling Systems.

Key Features:

- Combined Ring Power IN/OUT Isolator.
- Compatible with Copper (Cu) or Aluminium (Al) Feeder Cables from 16-120mm².
- Two Switched & Fused Output Functional Supplies.
- Functional Supply Fuse Carriers IEC60269 (ABB 10x38mm).
- Compliant to Network Rail specification NR/L2/ELP/27409 Issue 2.
- Dimensions W=400mm x H=300mm x D=221mm.
- Weight = 7.5Kg.

Support

All products come with a standard 12 month warranty with an option to extend if required and a minimum 35 year life expectancy. RSP has an experienced team on hand to provide ongoing support pre, during and after sales.



Contact us to order or get more info

Call us on **01752 969321**

Alternately you can fill out *our online form*



FSP04 - Type 07

FSP04 Type 07

WIRING DIAGRAM

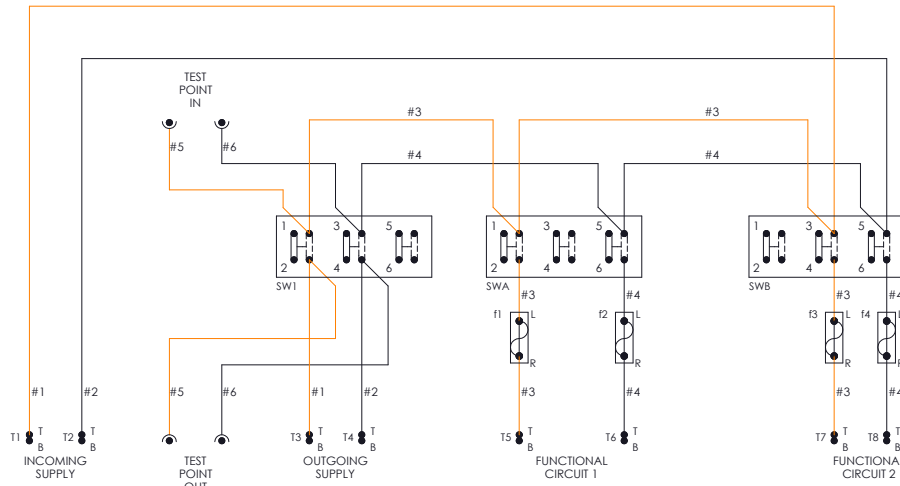

DIMENSIONING

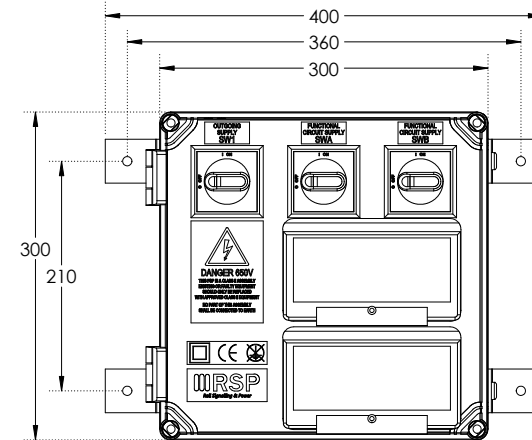

INTERNAL VIEW

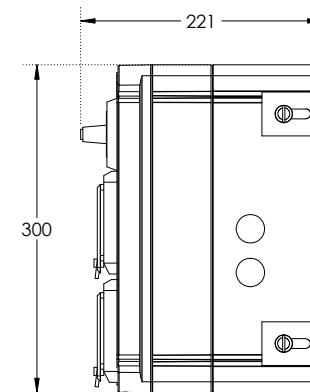
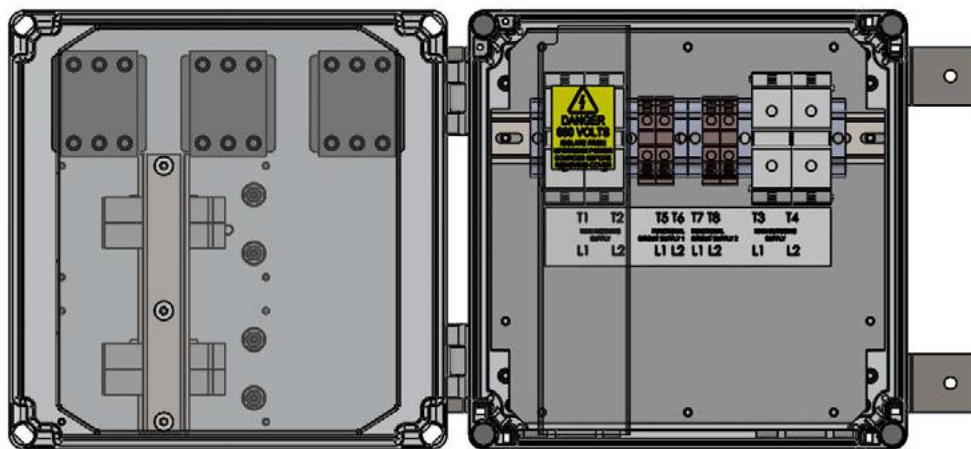



FSP04 - Type 08

FSP04 Switchgear Assembly - Type 08

- ❑ Railway Cat No. 092/002331.
- ❑ RSP Part No. DLLF4P0.
- ❑ Class II Distribution Enclosure for 650V Signalling Systems.

Key Features:

- ❑ Combined Ring Power IN/OUT Isolator.
- ❑ Compatible with Copper (Cu) or Aluminium (Al) Feeder Cables from 16-120mm².
- ❑ Two Switched & Fused Output Functional Supplies.
- ❑ Functional Supply Fuse Carriers BS88.
- ❑ Compliant to Network Rail specification NR/L2/ELP/27409 Issue 2.
- ❑ Dimensions W=400mm x H=300mm x D=221mm.
- ❑ Weight = 7.5Kg.

Support

All products come with a standard 12 month warranty with an option to extend if required and a minimum 35 year life expectancy. RSP has an experienced team on hand to provide ongoing support pre, during and after sales.



Contact us to order or get more info

Call us on **01752 969321**

Alternately you can fill out *our online form*



FSP04 - Type 08

FSP04 Type 08

WIRING DIAGRAM

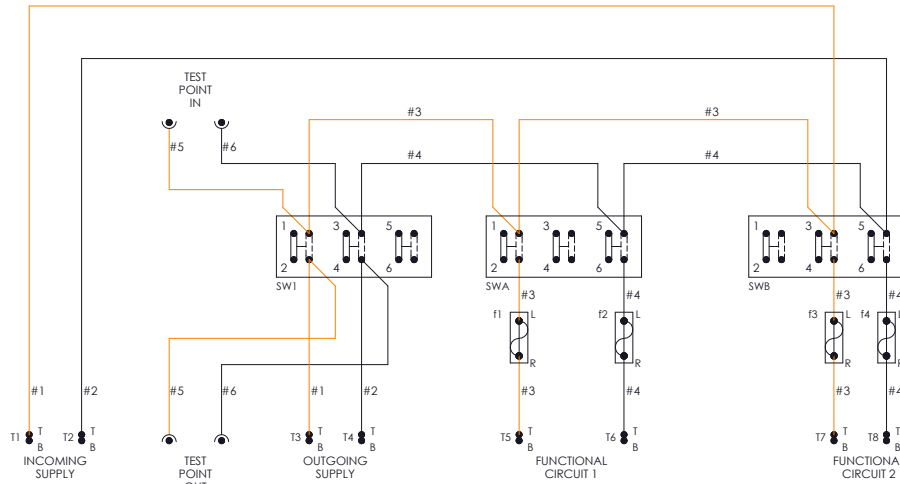

DIMENSIONING

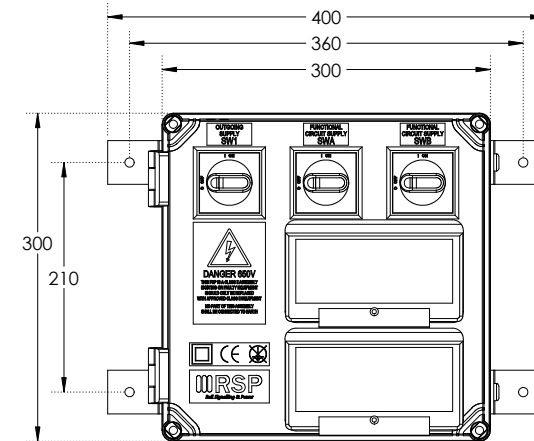

INTERNAL VIEW

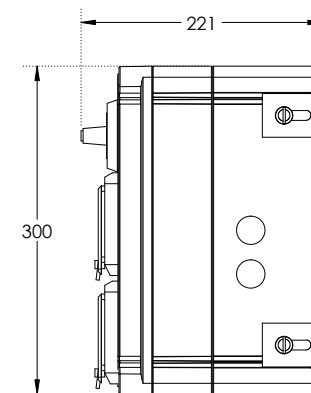
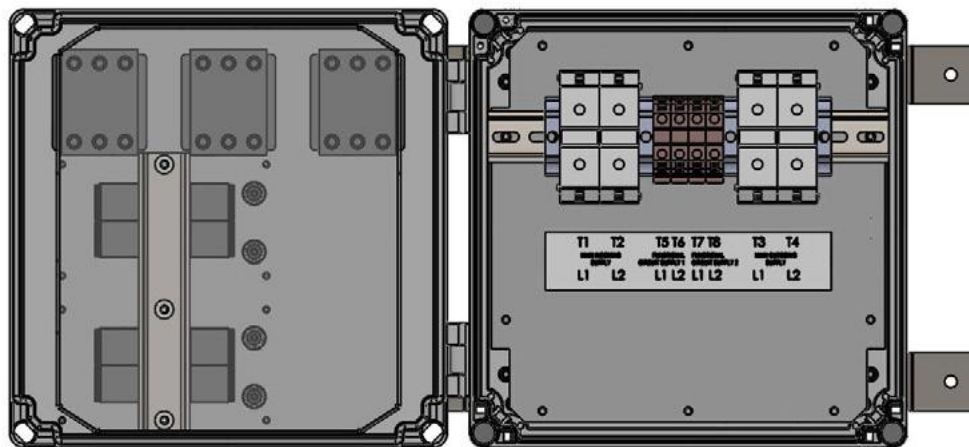



FSP04 - Type 09

FSP04 Switchgear Assembly - Type 09

- Railway Cat No. 092/002332.
- RSP Part No. DLLF4P09.
- Class II Distribution Enclosure for 650V Signalling Systems.
- Functional supplies share a common fuse.

Key Features:

- Dedicated Ring Power IN and OUT Isolators.
- Compatible with Copper (Cu) or Aluminium (Al) Feeder Cables from 16-120mm².
- Two Switched Output Functional Supplies sharing a common fuse.
- Functional Supply Fuse Carriers IEC60269 (ABB 10x38mm).
- Compliant to Network Rail specification NR/L2/ELP/27409 Issue 2.
- Dimensions W=400mm x H=300mm x D=221mm.
- Weight = 7.5Kg.

Support

All products come with a standard 12 month warranty with an option to extend if required and a minimum 35 year life expectancy. RSP has an experienced team on hand to provide ongoing support pre, during and after sales.



Contact us to order or get more info

Call us on **01752 969321**

Alternately you can fill out *our online form*



FSP04 - Type 09

FSP04 Type 09

WIRING DIAGRAM

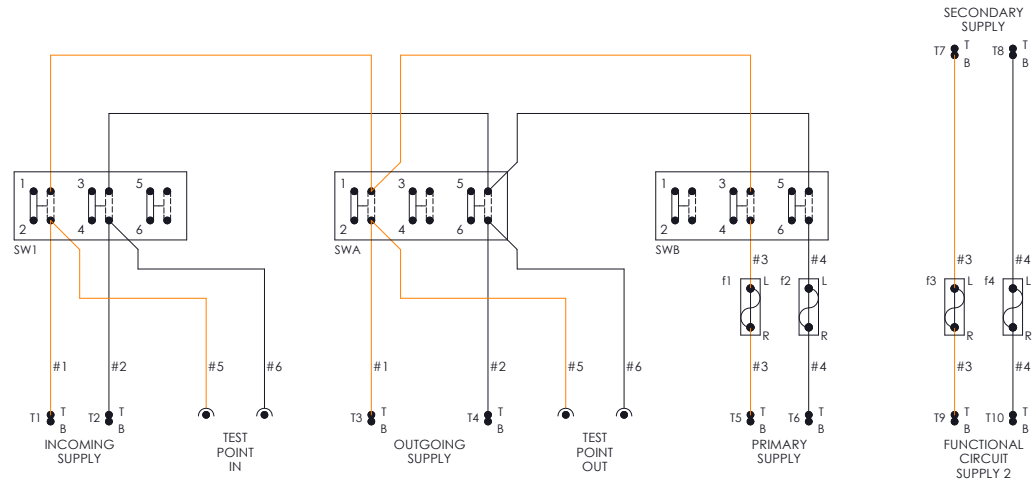

DIMENSIONING

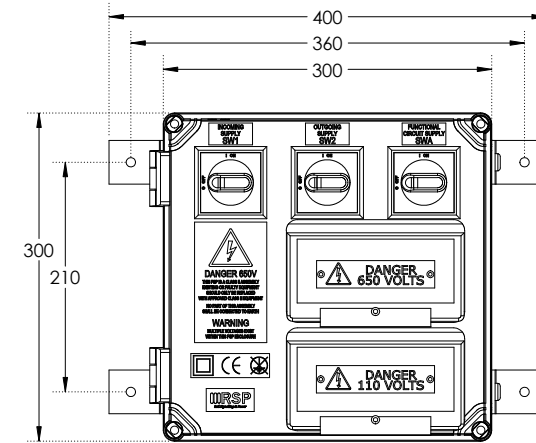

INTERNAL VIEW

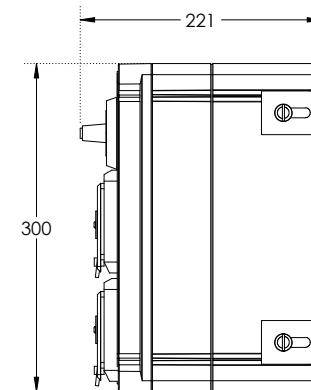
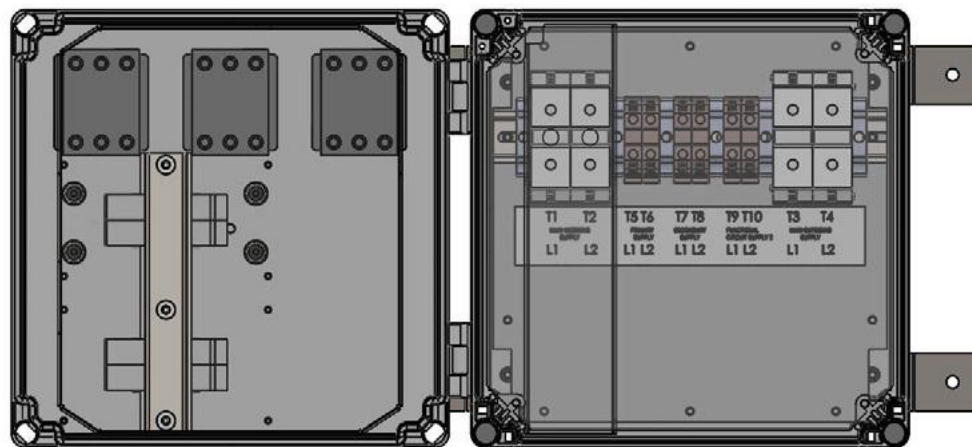

FSP04 - Type 10

FSP04 Switchgear Assembly - Type 10

- Railway Cat No. 092/002333.
- RSP Part No. DLLF4P10.
- Class II Distribution Enclosure for 650V Signalling Systems.
- Functional supplies share a common fuse.

Key Features:

- Dedicated Ring Power IN and OUT Isolators.
- Compatible with Copper (Cu) or Aluminium (Al) Feeder Cables from 16-120mm².
- Two Switched Output Functional Supplies sharing a common fuse.
- Functional Supply Fuse Carriers BS88.
- Compliant to Network Rail specification NR/L2/ELP/27409 Issue 2.
- Dimensions W=400mm x H=300mm x D=221mm.
- Weight = 7.5Kg.

Support

All products come with a standard 12 month warranty with an option to extend if required and a minimum 35 year life expectancy. RSP has an experienced team on hand to provide ongoing support pre, during and after sales.



Contact us to order or get more info

Call us on **01752 969321**

Alternately you can fill out *our online form*



FSP04 - Type 10

FSP04 Type 10

WIRING DIAGRAM

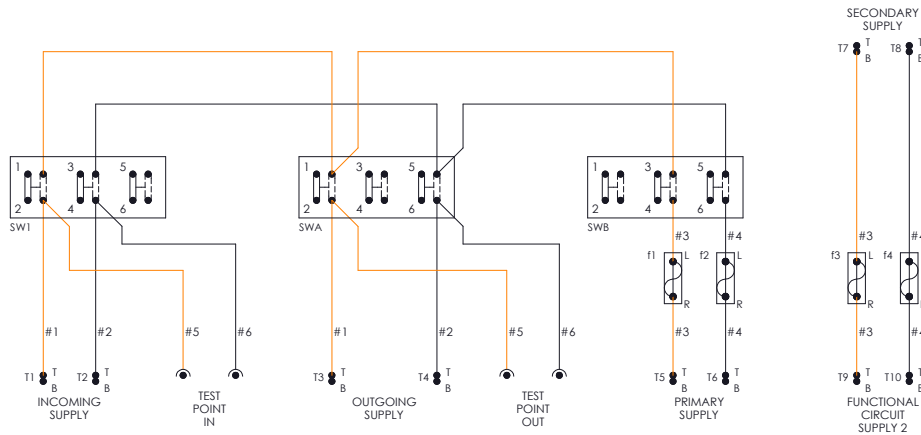

DIMENSIONING

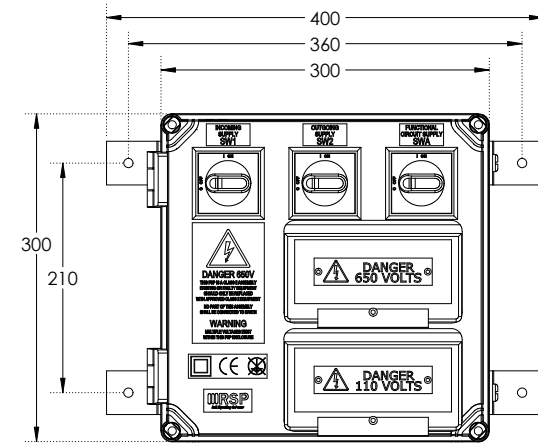

INTERNAL VIEW

